

Stock Lever Seal

Worksheet [R. 01.2015]

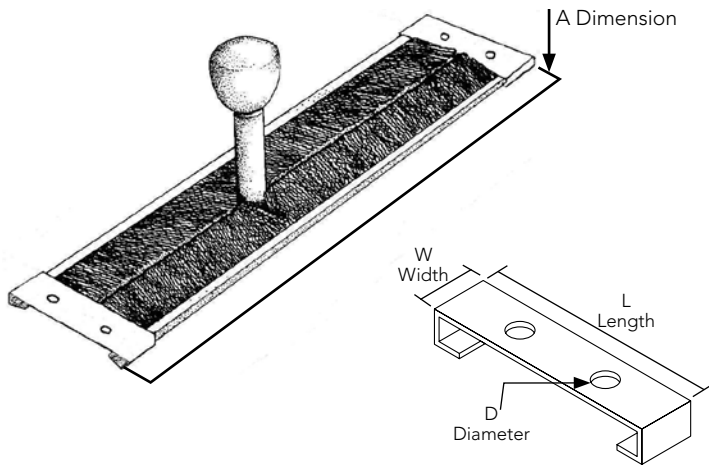

Contact Name: _____

Company Name: _____

Phone: _____

Fax: _____

Email: _____



CHANNEL DIMENSIONS

Section	X		Y	
	in.	mm	in.	mm
B	0.150	3.810	0.152	3.861
C	0.180	4.572	0.199	5.055
D	0.240	6.096	0.256	6.502

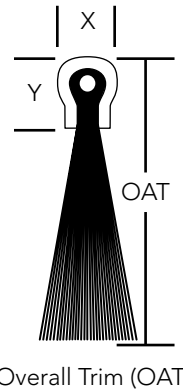

Overall Trim (OAT)

Specifications

Quantity: _____

Annual Usage: _____

Assembly Part Number: _____

"A" Dimension: _____

Application: _____

STOCK ASSEMBLIES

Part Number	Description
LSB103BC	Holds (2) Section B Brushes, .500" OAT Stock brush is SFB103BC, .008" nylon black crimped filament, galvanized steel channel
LSC110BC	Holds (2) Section C brushes, 1.20" OAT Stock brush is SFC110BC, .010" nylon black crimped filament, galvanized steel channel
LSD112BC	Holds (2) Section D brushes, 1.50" OAT Stock brush is SFD112BC, .010" nylon black crimped filament, galvanized steel channel

STOCK T-304 STAINLESS STEEL CLIPS

Fits Brush Channel	Length (L)		Width (W)		Hole Diameter (D)		Hole Spacing	
	in.	mm	in.	mm	in.	mm	in.	mm
B	1.060	26.924	0.316	8.026	0.138	3.505	0.340	8.636
C	2.460	62.484	0.315	8.001	0.138	3.505	0.807	20.498
D	3.060	77.724	0.500	12.700	0.190	4.826	1.236	31.394

Note: For brush filament types and diameters or channel materials not shown as stock, please ask for the Custom Lever Seal worksheet (IWCLS).